



is a new generation vibratory roller with the high comfort for an operator, up-to-date design with the "1 x 1m" visibility and with an extremely low gravity centre. Outstanding traction force enables enduring operation of the roller under hardest conditions and in slopes 30% and more. VV 910 D H is designed for small and medium and medium scale compaction of loose, semi-cohesive materials and stabilization. The machine is based on an articulated frame with a hydrostatic drive system of a smooth vibratory drum and two rubber tyred wheels. VV 910 PD H is designed for small and medium scale compaction of semi-cohesive and cohesive materials. The machine is based on an articulated frame with a hydrostatic drive system of a padded vibratory drum and two rubber tyred wheels. Direct drive of the rear wheels through the hydromotors with gearboxes enables a very low built in mounting of the driving power unit, by keeping the minimal length of the machine. It offers to the user the advantage of an excellent view from the operator's place and excellent machine stability and manoeuvrability in comparison with the other machines, which are equipped with the rigid driving axles. The vibration source is a double staged undirected vibration exciter, placed in the centre of the drum. The machine is equipped with a hydrostatic drive of all machine functions, Cummins engine, hydraulic Sauer-Danfoss. It fulfils the requirements of pollutants emission directives 97/68/ECE Stage 1 and EPA/CARB Tier 1. The machine meets the CE marking conditions. **Blade version available.**

STANDARD

VV 910 D H / VV 910 PD H

- Cabin ventilated and heated
- Two mode vibrator
- Articulated frame
- Heavy duty travel hydrostatic transmission
- Interaxle and interwheel ASC differential lock
- Working halogen headlights
- Hand-pump hood and cabin tilting
- Tyres 14,9-24 TT tread R1 (TD-02) (8PR)
- Tyres ballast liquid filling to -25 centigrades
- Painting STA: yellow, grey

OPTIONS

VV 910 D H / VV 910 PD H

- Operator platform without cabin with rails
- Lockable vandal guard
- Dozing blade
- Electrohydraulic cabin and hood tilting
- ROPS protection (obligatory for CE)
- Cabin FOPS protection
- ROPS canvas canopy (mounted to ROPS)
- FOPS sun roof (mounted to ROPS)
- Air conditioning
- Tyres 14,9-24 tread R3 (8 PR) instead of standard ones
- Compaction indicator
- Compaction indicator printer
- Alternator safety screen
- Fan safety screen
- Turn indicators
- Beacon
- Back up alarm
- Engine speed indicator
- Special painting

VV 910 D H

- Segment kit 120 pad

MAXIMAL COMPACTED LIFT THICKNESS AT OPTIMAL WORKING CONDITIONS (m)

	Rockfill	Sand/Gravel	Mixed soils	Silt	Clay	Stabilization
VV 910 D H	-	0,50 m	0,40 m	0,30 m	0,20 m	-
VV 910 PD H	-	-	0,40 m	0,30 m	0,25 m	-



STAVOSTROJ, a.s.
 Náchodská 145, 549 01 Nové Město nad Metují, Czech Republic
 phone: +420 491 476 111
 fax: +420 491 470 215, 491 470 405
 e-mail: stavo@sta.cz, stasales@sta.cz, www.sta.cz

CERTIFICATED:
ISO 9001

VV 910 D H VV 910 PD H



SINGLE DRUM ROLLERS - SMOOTH & PADDED (9 t)

size (mm)	A	D	D1	G	G1	H	H1	L	T	W	W1	W2
VV 910 D H	2560	1300		385	375	2870	2200	5195	25	1680	1930	120
VV 910 PD H	2560	1240	1400	385	375	2870	2200	5195	15	1680	1930	120

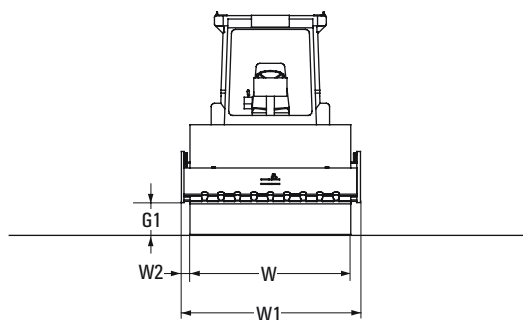
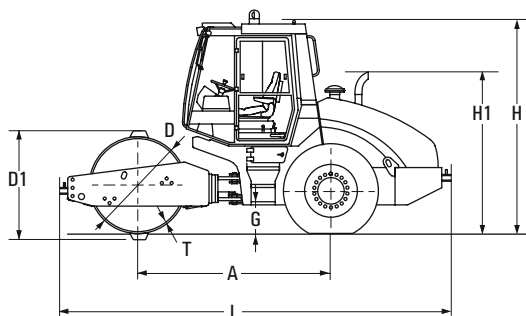

CAPACITY

	VV 910 D H	VV 910 PD H
Operating weight (CECE)	8880 kg	8825 kg

WEIGHTS

Operating weight maximum	8995 kg	8940 kg
Drum load - CECE	5375 kg	5320 kg
Axle load, wheels CECE	3505 kg	3505 kg
Static linear load	32,0 kg/cm	

DRUM

No. of pad feet		104
Height of pad		80 mm
Contact area of one pad foot		114 cm ²

STEERING

Steering angle (+ -)	36 deg	36 deg
Oscillation angle (+ -)	12 deg	12 deg
Turning radius inner (edge)	3090 mm	3090 mm
Transversal stability - straight	33 deg	33 deg

RIDING CHARACTERISTIC

No. of travel speeds	4	4
Maximal speed	8,5 km/h	8,5 km/h
Gradeability without vibration	55 %	55 %
Gradeability with vibration	55 %	55 %

BRAKES

Operation	Hydrostatic	Hydrostatic
Parking	Multi disc	Multi disc
Emergency	Multi disc	Multi disc

VIBRATION

Amplitudes	1,7 / 0,86 mm	1,7 / 0,86 mm
Frequencies	30 / 40 Hz	30 / 40 Hz
Centrifugal forces	160 / 145 kN	160 / 145 kN

TANKS

Fuel	275 lt	275 lt
------	--------	--------

ELEKTROINSTALLATION

Voltage	24 V	24 V
Capacity of batteries	2x61 Ah	2x61 Ah

ENGINE

Make	Cummins	Cummins
Type	4BT3.9-C99	4BT3.9-C99
Rated power	74 kW	74 kW
Standard	ISO 3046/1 (DIN 6271)	ISO 3046/1 (DIN 6271)

Technical modifications and data reserved. Machines may be shown with options.



STAVOSTROJ, a.s.

Náchodská 145, 549 01 Nové Město nad Metují, Czech Republic

phone: +420 491 476 111

fax: +420 491 470 215, 491 470 405

e-mail: stavo@sta.cz, stasales@sta.cz, www.sta.cz

CERTIFICATED:
ISO 9001